

**Sierra County  
Board of Supervisors'  
Agenda Transmittal &  
Record of Proceedings**

<b>MEETING DATE:</b> March 2 , 2019	<b>TYPE OF AGENDA ITEM:</b> <input checked="" type="checkbox"/> Regular <input type="checkbox"/> Timed <input type="checkbox"/> Consent
--	---

<b>DEPARTMENT:</b> Department of Public Works and Transportation <b>APPROVING PARTY:</b> Tim H. Beals, Director <b>PHONE NUMBER:</b> 530-289-3201
---

**AGENDA ITEM:** Adoption of Resolution abandoning a portion of an offer of dedication that was offered in perpetuity to the County as part of the approval of the Sierra Valley Senior Community located on Hill Street adjacent to the City of Loyalton.

**SUPPORTIVE DOCUMENTS ATTACHED:** Memo Resolution Agreement Other

**BACKGROUND INFORMATION:** A Resolution of Intent was adopted on February 5, 2019 and a public hearing was opened on March 5, 2019 and is continued to March 19, 2019. An updated description of the proposed vacation is being provided based on the outcome of the March 19, 2019 meeting and a special meeting is scheduled to complete this process.

**FUNDING SOURCE:**  
**GENERAL FUND IMPACT:** No General Fund Impact  
**OTHER FUND:**  
**AMOUNT:** \$ N/A

**ARE ADDITIONAL PERSONNEL REQUIRED?**  
  
Yes, -- --  
No

**IS THIS ITEM ALLOCATED IN THE BUDGET?** Yes No  
  
**IS A BUDGET TRANSFER REQUIRED?** Yes No

**SPACE BELOW FOR CLERK'S USE**

<p><b>BOARD ACTION:</b> <input type="checkbox"/>Approved <input type="checkbox"/>Approved as amended <input type="checkbox"/>Adopted <input type="checkbox"/>Adopted as amended <input type="checkbox"/>Denied <input type="checkbox"/>Other <input type="checkbox"/>No Action Taken</p>	<p><input type="checkbox"/>Set public hearing For: _____ <input type="checkbox"/>Direction to: _____ <input type="checkbox"/>Referred to: _____ <input type="checkbox"/>Continued to: _____ <input type="checkbox"/>Authorization given to: _____</p>	<p>Resolution 2019- _____ Agreement 2019- _____ Ordinance _____ Vote: Ayes: Noes: Abstain: Absent: <input type="checkbox"/>By Consensus</p>
--	---	---

**COMMENTS:**  
\_\_\_\_\_  
\_\_\_\_\_  
\_\_\_\_\_  
\_\_\_\_\_  
\_\_\_\_\_

\_\_\_\_\_  
CLERK TO THE BOARD DATE

**WHEN RECORDED MAIL DOCUMENT TO:**

**Tim H. Beals  
Sierra County  
Director of Transportation  
Post Office Box 98  
Downieville, CA 95936**

---

**STATE OF CALIFORNIA, COUNTY OF SIERRA, BOARD OF SUPERVISORS**

**IN THE MATTER OF VACATION OF A  
PORTION OF A STREET, HIGHWAY OR PUBLIC EASEMENT  
AFFECTING AN OFFER OF DEDICATION ON HILL STREET  
ADJACENT TO THE CITY OF LOYALTON**

**RESOLUTION NO. 2019-\_\_\_\_\_**

**WHEREAS**, on February 5, 2019 the Sierra County Board of Supervisors adopted Resolution 2019-021 setting a date for a public hearing and declaring intent to vacate a portion of an irrevocable offer of dedication as shown on Book 5, MS Page 76, affecting a portion of lot 1 of the Parcel Map for a Subdivision in Two parts for Gwendolyn Lynch, March 1978, the parcel of land whereupon the Sierra Senior Apartments are located; and,

**WHEREAS**, Notice of Public Hearing for March 5, 2019 was duly published and posted as required by law.

**NOW, THEREFORE, BE IT RESOLVED** that the Board of Supervisors of the County of Sierra find as follows:

- A) The Sierra County Board of Supervisors duly published public hearing notices, posted public hearing notices on or near the property and in public places and reviewed public testimony and staff reports as part of the record of proceedings for a public hearing conducted on March 5, 2019 and continued to March 19, 2019 at which time the public hearing was closed.
- B) The Board determined that a vacation of a portion of the offer of dedication as shown on the map attached hereto as Exhibit A and the legal description of the proposed vacation as described in Exhibit B would be in the public interest and therefore approves and orders such vacation.
- C) Based upon the record, the proposed vacation shall be exempt from the California Environmental Quality Act, and the Planning Director is directed to file the appropriate exemption form with the County Recorder upon recordation of this resolution.

D) The Clerk of the Board is directed to record this resolution consistent with the law.

**Adopted** by the Board of Supervisors of the County of Sierra, State of California on the 21st day of March, 2019 by the following vote:

AYES:

NOES:

ABSTAIN:

ABSENT:

COUNTY OF SIERRA

---

PAUL ROEN  
CHAIRMAN, BOARD OF SUPERVISORS

ATTEST:

APPROVED AS TO FORM:

---

HEATHER FOSTER  
CLERK OF THE BOARD

---

DAVID PRENTICE  
COUNTY COUNSEL

510.000  
N89° 58' 27.00"W

33' COUNTY OF SIERRA  
CENTER SECTION 13

HILL ST.



PORTION 1  
SEE DETAIL 'B' FOR  
ENLARGED VIEW

PORTION 2  
SEE DETAIL 'A' FOR  
ENLARGED VIEW

S00° 03' 00.00"E  
854.250

N00° 03' 00.00"W  
854.250

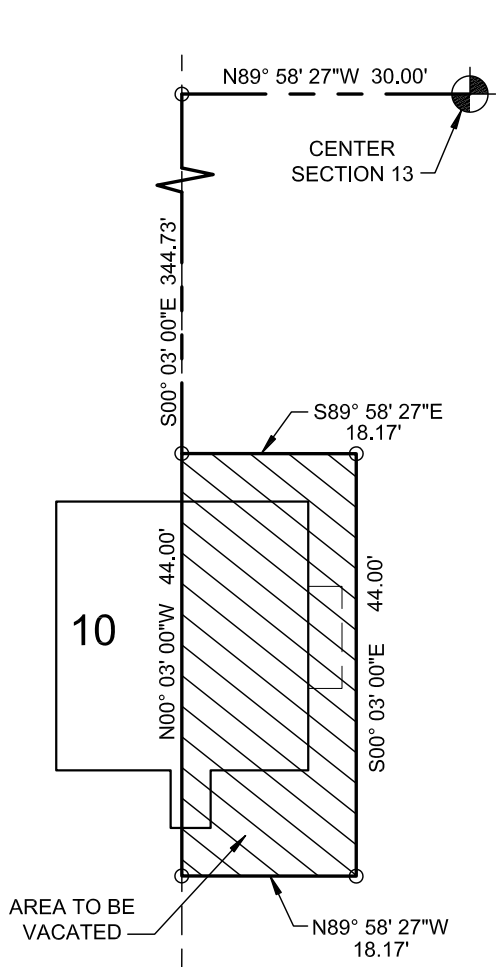

**DETAIL 'A'**  
**PORTION 2**  
SCALE 1"=20'

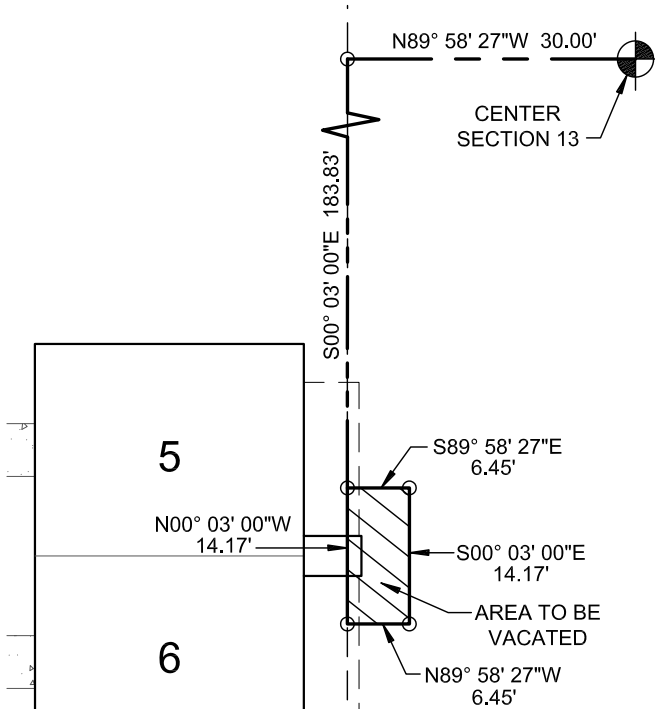

**DETAIL 'B'**  
**PORTION 1**  
SCALE 1"=20'

AN OFFER OF DEDICATION FOR ROAD AND ALL UTILITIES AND INCIDENTAL PURPOSES, RECORDED JULY 13, 1978 AS BOOK 78, PAGE 685 OF OFFICIAL RECORDS.  
TO: COUNTY OF SIERRA, A POLITICAL SUBDIVISION  
(AFFECTS EASTERLY 30 FEET OF APN 016-040-079-0 AND WESTERLY 30 FEET OF APN 016-040-099-0)

AN EASEMENT FOR ROAD AND UTILITY AND INCIDENTAL PURPOSES IN THE DOCUMENT RECORDED AUGUST 08, 1978 AS BOOK 79, PAGE 193 OF OFFICIAL RECORDS.  
(AFFECTS THE EASTERLY 30 FEET)

S89° 58' 27.00"E  
510.000

**bda** **Bisnett Design Associates**  
16046 Bear Court  
Grass Valley, CA 95949  
530.277.9733  
bda@bisnettdesign.com

Landscape Architecture & Environmental Planning

MARCH 20, 2019

**OFFER OF DEDICATION  
VACATION AREA SKETCH MAP**

**EXHIBIT 'A'**



NORTH

CAUTION: GRAPHIC SCALE MUST BE USED EXCEPT WHERE DIMENSIONED

**EXHIBIT B:**

**Sierra Seniors Offer of Dedication Vacation Legal Description**

**DESCRIPTION OF PORTIONS OF OFFER OF DEDICATION AREA TO BE VACATED:**

Two portions of the Offer of Dedication, recorded July 13, 1976 as BOOK 78, PAGE 685 of Official Records; more particularly described as follows:

**Portion 1:** Beginning at a point along the western line of said offer of dedication from which the center of Section 13, Township 21, North, Range 15 East, M.D.M. bears North 00 degrees 03 minutes 00 seconds West for a distance of 183.83 feet; THENCE South 89 degrees 58 minutes 27 seconds East for a distance of 30.00 feet; THENCE FROM SAID POINT OF BEGINNING South 89 degrees 58 minutes 27 seconds East for a distance of 6.45 feet; THENCE South 00 degrees 03 minutes 00 seconds East for a distance of 14.17 feet; THENCE North 89 degrees 58 minutes 27 seconds West for a distance of 6.45 feet to a point along the western line of said offer of dedication; THENCE North 00 degrees 03 minutes 00 seconds West for a distance of 14.17 feet along the western line of said offer of dedication to the point of beginning.

**Portion 2:** Beginning at a point along the western line of said offer of dedication from which the center of Section 13, Township 21, North, Range 15 East, M.D.M. bears North 00 degrees 03 minutes 00 seconds West for a distance of 344.73 feet; THENCE South 89 degrees 58 minutes 27 seconds East for a distance of 30.00 feet; THENCE FROM SAID POINT OF BEGINNING South 89 degrees 58 minutes 27 seconds East for a distance of 18.17 feet; THENCE South 00 degrees 03 minutes 00 seconds East for a distance of 44.00 feet; THENCE North 89 degrees 58 minutes 27 seconds West for a distance of 18.17 feet to a point along the western line of said offer of dedication; THENCE North 00 degrees 03 minutes 00 seconds West for a distance of 44.00 feet along the western line of said offer of dedication to the point of beginning.